



PRODUCT DATASHEET

RANCH B 219/500 - RANCH B 219/700

Fix bollard

Fixed bollard for bolting to the floor. Diameter and dimensions are the same as the automatic models. Available in two dimensios.

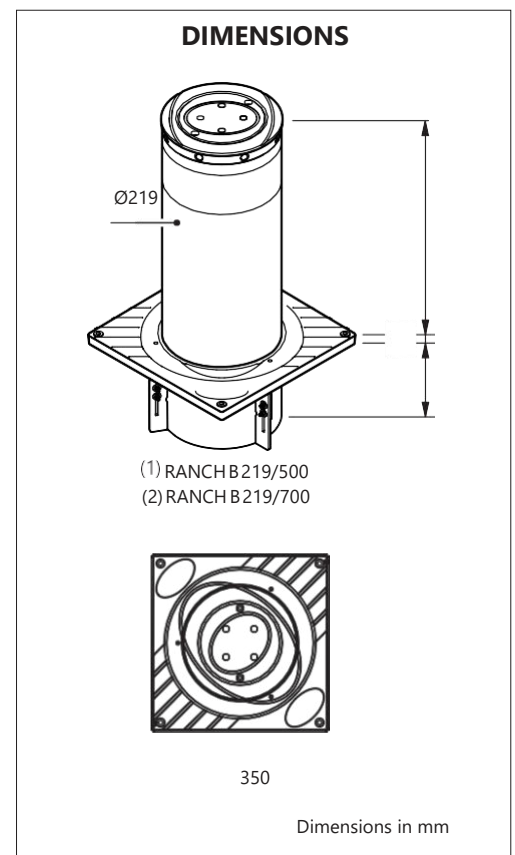

Fixed Bollard

- *Break-in resistance: **150 000 J**
- *Painted stem: stainless steel (optional)
- *Adhesive film-reflectorized band, customizable (optional)
- *Bollard top cover with led lights (optional)

REFERENCE STANDARDS

2004/108/CEE; 93/68/CEE (EN55014-1; EN55014-2) •
Electromagnetic Compatibility 2006/95/CEE;
93/68/CEE (EN60335-1(2002)) • Low voltage
2006/42/CEE (EN60204-1) • Machinery directive



TECHNICAL-ENVIRONMENTAL MAIN FEATURES		
Rod out of the ground	RANCH B 219/500: Ø219 x h.490 x sp.5 mm steel Fe 360 (S 235 JR) *	RANCH B 219/700: Ø219 x h.700 x sp.5 mm steel Fe 360 (S 235 JR) *
Buried structure	RANCH B 219/500: Ø219 x h.178	RANCH B 219/700: Ø219 x h.218
Foundation	Concrete	
Excavation	500 x 500 x h.400 mm	
Break-in resistance	150 000 J	
Driven rod treatment	Cataphoresis and coating RAL7015 standard, other colour on request	
Passive visibility	Reflective film **	
Flange	Cast iron, cataphoresis black	
Top cover	Cast iron, cataphoresis black	
Net weight	RANCH B 219/500: 30 kg	RANCH B 219/700: 37 kg
Gross weight	RANCH B 219/500: 45 kg	RANCH B 219/700: 53 kg

*Option, AISI304 OR AISI316

**Customizable (optional)

ELECTRICAL FEATURES (optional)	
Light power supply	ALLU 24Vac 24 Vac ±10%, 50-60 Hz
Power	Light cable 24 Vac ±10%, 50-60 Hz (up to 80 bollards)
Power consumption	1 W for each bollard
Signalling	On the top with high intensity LEDs (optional)

For system composition and installation refer to the regulations in force in the country where the system is being installed.

ITEM SPECIFICATION

Fixed bollard for bolting to the floor. Diameter and dimensions the same as the automatic models. Available in two sizes:

-Ø219 x h.499 x th.5 mm, steel Fe 360 (S 235 JR). Finishing: cataphoresis, powder paint. Break-in resistance 150 000 J.

Adhesive reflecting strip. Top cover compatible with high-brightness LED lights.

Ø219 x h.700 x th.5 mm, steel Fe 360 (S 235 JR). Finishing: cataphoresis, powder paint. Break-in resistance 150 000 J. Adhesive reflecting strip.

BB Moss
Skredderveien 142
1537 Moss

Tlf: +47 466 50 500
Mail: post@bbmoss.no
www.bbmoss.no